



ekho



# EK-WL8-CP/AU

## Hybrid Wireless Manual Call Point

### Features

- ▶ Approved to AS ISO 7240 Parts 11 & 25
- ▶ RED compliant
- ▶ Bi-directional wireless communication
- ▶ Self optimising wireless amplitude and frequency
- ▶ Tamper switch
- ▶ Utilises standard low cost lithium battery technology
- ▶ Up to 10 years battery life\*
- ▶ Resettable Element
- ▶ Clear 'device activated' warning flag

### Description

A Wireless Resettable Manual Call Point which features a simulated glass front.



When activated, a plastic 'flag' is displayed in the window of the unit; the supplied key will reset the flag and unit. Supplied with back box.

### Specifications

Ordering code	EK-WL8-CP/AU	
Operating frequency range	918 - 926 MHz	
Communication range (in open air)	1200 m	
Modulation type	GFSK	
Operating frequency channels	6	
Max. radiated power	≤ 25 mW	
Time period between wireless signal transmissions	2 minutes	
Operating temperature range	- 10 °C to + 55 °C	
Max. tolerated humidity	95% RH (non condensing)	
Dimensions (mm)	H 87 x W 87 x D 62	
Power supply (Dual 3V lithium batteries)	1 x Primary cell (CR123A)	1 x Secondary cell (CR2032A)
	1.2 Ahr	0.24 Ahr
	Up to 10 years primary battery life*	3 months secondary battery life

### Standards & Approvals

AS ISO 7240-11 Call Points

AS ISO 7240-25 Components using radio links



\*Dependant on operational usage



ISS1  
OCT20



# EK-WL8-EXP/AU

## Hybrid Wireless Expander Module

### Features

- ▶ Approved to AS ISO 7240 Parts 18 & 25
- ▶ RED compliant
- ▶ Supports MESH communications
- ▶ Bi-directional wireless communication
- ▶ Self optimising wireless amplitude and frequency
- ▶ Makes additions to existing wired systems easy and cost effective
- ▶ Requires external power supply (24 VDC).



### Description

The EK-WL8-EXP/AU Expander Module increases radio coverage of an Ekho Translator Module, allowing the use of the system in larger buildings and in difficult wireless environments. Multiple Expanders can be utilised in a micro cell structure to provide a solution to large, complex systems.

When multiple Expander Modules (two or more) are used, these provide a MESH solution maintaining the wireless systems integrity. The system allows up to 126 Expander Modules or field devices to be configured to any one Translator Module\*.

Any combination of Ekho wireless devices can be connected to the Expander Module\*. The Expander Module transmits the intelligent device information from the field devices to the Loop Translator Module using a highly stable bi-directional radio communication protocol. The system parameters are programmed into the Expander Module via the Translator Module.

The Expander Module Is fitted with two Internal antennas reducing signal fading and ensuring reliable radio communications. Optional back box available.

### Specifications

Ordering code	EK-WL8-EXP/AU	Optional Back box is available (EK-BBOX-01)
Operating frequency range	918 - 926 MHz	
Communication range (in open air)	1200 m	
Modulation type	GFSK	
Operating frequency channels	6	
Max. radiated power	≤ 25 mW	
Time period between wireless signal transmissions	2 minutes	
Current consumption	80 mA	
Operating voltage	11 - 28 VDC	
Operating temperature range	- 10 °C to + 55 °C	
Max. tolerated humidity	93% RH (non-condensing)	
Weight (g) / Dimensions (mm)	320 / H 143 x W 210 x D 42 without Back box	

### Standards & Approvals

AS ISO 7240-18 Input/Output Devices

AS ISO 7240-25 Components using radio links



\*Dependant on available loop address capacity



# EK-WL8-H/AU

## Hybrid Wireless A1R Heat Sensor

### Features

- ▶ Approved to AS ISO 7240 Parts 5 & 25
- ▶ RED compliant
- ▶ Internal algorithm processing for optimal performance
- ▶ Tamper switch
- ▶ Up to 10 years battery life\*
- ▶ Utilises standard low cost lithium battery technology
- ▶ Bi-directional wireless communications
- ▶ Self optimising wireless amplitude and frequency
- ▶ Compatible with Ekho Translator/Expander module.



### Description

The EK-WL8-H/AU is a wireless A1R heat sensor. It is a fully intelligent device and compatible with the Ekho wireless Translator and Expander modules.

The sensor is designed for installations where smoke detection technology is not suitable.

The well-proven adaptive radio signal processing algorithms ensure the highest levels of life safety and system reliability are achieved. An in-built magnet test allows easy activation to verify correct functionality and response.

### Specifications

Ordering code	EK-WL8-H/AU	
Operating frequency range	918 - 926 MHz	
Communication range (in open air)	1200 m	
Modulation type	GFSK	
Operating frequency channels	6	
Max. radiated power	≤ 25 mW	
Class A1R	58 °C max.	
Operating temperature range	- 10 °C to + 55 °C	
Max. tolerated humidity (non condensing)	95% RH	
Dimensions (mm)	160 / ø 111 x H 65	
Power supply (Dual 3V lithium batteries)	1 x Primacy cell (CR123A)	1 x Secondary cell (CR2032A)
	1.2 Ahr	0.24 Ahr
	Up to 10 years primary battery life*	3 months

### Standards & Approvals

AS ISO 7240-5 Heat Point Detectors

AS ISO 7240.25 Components using radio links



\*Dependant on operational usage



# EK-WL8-OH/AU

## Hybrid Wireless Multi-Sensor

### Features

- ▶ Approved to AS ISO 7240 Parts 5,7,25 & 29
- ▶ RED compliant
- ▶ Internal algorithm processing optimises performance
- ▶ Tamper switch
- ▶ Up to 10 years battery life\*
- ▶ Utilises standard low-cost lithium battery technology
- ▶ Bi-directional wireless communications
- ▶ Self optimising wireless amplitude and frequency
- ▶ Compatible with all Ekho Translator/Expander modules.



### Description

The EK-WL8-OH/AU is the latest in wireless multi-criteria sensor technology. It is a fully intelligent device and compatible with the Ekho wireless Translator and Expander modules.

The sensor combines both smoke and (A1R) heat detection technologies for improved performance, which can contribute to reducing unwanted alarms.

Utilising well-proven adaptive radio signal processing algorithms ensures that the highest levels of life safety and system reliability are achieved.

An in-built magnet test allows easy activation to verify correct functionality and response.

### Specifications

Ordering code	EK-WL8-OH/AU		
Operating frequency range	918 - 926 MHz		
Communication range (in open air)	1200 m		
Modulation type	GFSK		
Operating frequency channels	6		
Max. radiated power	≤ 25 mW		
Operating modes	Smoke only	A1R Heat only	Smoke and A1R Heat combined
Operating temperature range	- 10 °C to + 55 °C		
Max. tolerated humidity	95% RH (non-condensing)		
Weight (g) / Dimensions (mm)	160 / ø 111 x H 57		
Power supply (Dual 3V lithium batteries)	1 x Primacy cell (CR123A)		1 x Secondary cell (CR2032A)
	1.2 Ahr		0.24 Ahr
	Up to 10 years primary battery life*		3 months secondary battery life

### Standards & Approvals

AS ISO 7240-5 Heat Point Detectors

AS ISO 7240-7 Smoke Detectors

AS ISO 7240-25 Components using radio links



\*Dependant on operational usage



ISS1  
OCT20

For further information visit [www.hochikiaustralia.com/ekho](http://www.hochikiaustralia.com/ekho)

Hochiki Australia Pty Ltd. reserves the right to alter the specification of its products from time to time without notice. Although every effort has been made to ensure the accuracy of the information contained in this document it is not warranted or represented by Hochiki Australia Pty Ltd. to be a complete and up-to-date description.



# EK-WL8-IN/AU

## Hybrid Wireless Single Input Module

### Features

- ▶ Approved to AS ISO 7240 Parts 18 & 25
- ▶ RED compliant
- ▶ Monitored Input
- ▶ Bi-directional wireless communication
- ▶ Self optimising wireless amplitude and frequency
- ▶ Tamper Switch
- ▶ Up to 10 years battery life\*.

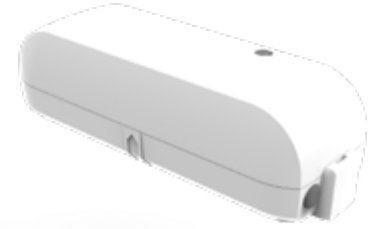

### Description

The EK-WL8-IN/AU is a Single Channel Input Module providing a convenient and cost effective solution for monitoring third party equipment.

The module is also controllable from the Fire Control Panel via the cause and effect programming and offers the same level of flexibility as a standard addressable module. Optional back box available.

### Specifications

Ordering code	EK-WL8-IN/AU	Optional Back box is available EK-BOX-02
Operating frequency range	918 - 926 MHz	
Communication range (in open air)	1200 m	
Modulation type	GFSK	
Operating frequency channels	6	
Max. radiated power	≤ 25 mW	
Time period between wireless signal transmissions	2 minutes	
Operating temperature range	- 10 °C to + 55 °C	
Max. tolerated humidity	95% RH (non-condensing)	
Weight (g) / Dimensions (mm)	70 / H 109 x W 37 x D 30 (without back box)	
Power supply (Dual 3V lithium batteries)	1 x Primacy cell (CR123A)	1 x Secondary cell (CR2032A)
	1.2 Ahr	0.24 Ahr
	Up to 10 years primary battery life*	3 months secondary battery life

### Standards & Approvals

AS ISO 7240-18 Input/Output devices

AS ISO 7240-25 Components using radio links



\*Dependant on operational usage



ISS1  
OCT20

For further information visit [www.hochikiaustralia.com/ekho](http://www.hochikiaustralia.com/ekho)

Hochiki Australia Pty Ltd. reserves the right to alter the specification of its products from time to time without notice. Although every effort has been made to ensure the accuracy of the information contained in this document it is not warranted or represented by Hochiki Australia Pty Ltd. to be a complete and up-to-date description.



# EK-WL8-O/AU

## Hybrid Wireless Optical Smoke Sensor

### Features

- ▶ Approved to AS ISO 7240 Parts 7 & 25
- ▶ RED compliant
- ▶ Internal algorithm processing for optimal performance
- ▶ Tamper switch
- ▶ Up to 10 years battery life\*
- ▶ Utilises standard low cost lithium battery technology
- ▶ Bi-directional wireless communications
- ▶ Self optimising wireless amplitude and frequency
- ▶ Compatible with all Ekho Translator/Expander modules.



### Description

The EK-WL8-O/AU wireless optical smoke sensor is the latest in wireless smoke sensor technology. It is a fully intelligent device and compatible with the Ekho wireless Translator and Expander modules.

The sensor utilises optical smoke detection technologies and algorithms for improved performance, which can contribute to reducing unwanted alarms.

Utilising well-proven adaptive radio signal processing algorithms ensure the highest levels of life safety and system reliability are achieved.

An in-built magnet test allows easy activation to verify correct functionality and response.

### Specifications

Ordering code	EK-WL8-O/AU	
Operating frequency range	918 - 926 MHz	
Communication range (in open air)	1200 m	
Modulation type	GFSK	
Operating frequency channels	6	
Max. radiated power	≤ 25 mW	
Operating temperature range	- 10 °C to + 55 °C	
Max. tolerated humidity (non condensing)	95% RH	
Dimensions (mm)	ø 111 x H 57	
Power supply (Dual 3V lithium batteries)	1 x Primary cell (CR123A)	1 x Secondary cell (CR2032)
	1.2 Ahr	1.2 Ahr
	Up to 10 years primary battery life*	8 months secondary battery life

### Standards & Approvals

AS ISO 7240-7 Smoke Detectors

AS ISO 7240-25 Components using radio links



\*Dependant on operational usage



ISS1  
OCT20

For further information visit [www.hochikiaustralia.com/ekho](http://www.hochikiaustralia.com/ekho)

Hochiki Australia Pty Ltd. reserves the right to alter the specification of its products from time to time without notice. Although every effort has been made to ensure the accuracy of the information contained in this document it is not warranted or represented by Hochiki Australia Pty Ltd. to be a complete and up-to-date description.



# EK-WL8-OUT/AU

## Hybrid Wireless Single Output Module

### Features

- ▶ Approved to AS ISO 7240 Parts 18 & 25
- ▶ RED compliant
- ▶ Contact is configured as 24 VDC output Bi-directional wireless communication Up to 10 years battery life\*
- ▶ Self optimising wireless amplitude and frequency
- ▶ Includes a fault monitoring input
- ▶ Requires external power supply (24V DC).



### Description

A Wireless Single Channel Output Module which allows the control panel to switch the circuits of an external device wirelessly via an Ekho Translator/ Expander module.

The unit provides a switched voltage output (24 VDC recommended) only. Optional back box is available.

### Specifications

Ordering code	EK-WL8-OUT/AU	Optional Back box is available EK-BBOX-01
Operating frequency range	918 - 926 MHz	
Communication range (in open air)	1200 m	
Modulation type	GFSK	
Operating frequency channels	6	
Max. radiated power	≤ 25 mW	
Time period between wireless signal transmissions	2 minutes	
External power supply voltage	12 - 24 VDC	
Operating temperature range	- 10 °C to + 55 °C	
Switched voltage rating*2	30 VDC / 250 VAC @ 8A	
Max tolerated humidity	93% RH (non-condensing)	
Weight (g) / Dimensions (mm)	350 / H 143 x W 210 x D 42 without Back box	
Power supply (Dual 3V lithium batteries)	1 x Primary cell (CR123A)	1 x Secondary cell (CR123A)
	1.2 Ahr	1.2 Ahr
	Up to 10 years primary battery life*	8 months secondary battery life

### Standards & Approvals

AS ISO 7240-18 Input/Output devices

AS ISO 7240-25 Components using Radio Links



\*Dependant on operational usage \*2Supply voltage dependant



For further information visit [www.hochikiaustralia.com/ekho](http://www.hochikiaustralia.com/ekho)  
Hochiki Australia Pty Ltd. reserves the right to alter the specification of its products from time to time without notice. Although every effort has been made to ensure the accuracy of the information contained in this document it is not warranted or represented by Hochiki Australia Pty Ltd. to be a complete and up-to-date description.





# EK-WL8-OUT/AU

Hybrid Wireless Single Output Module

## Relay Diagram

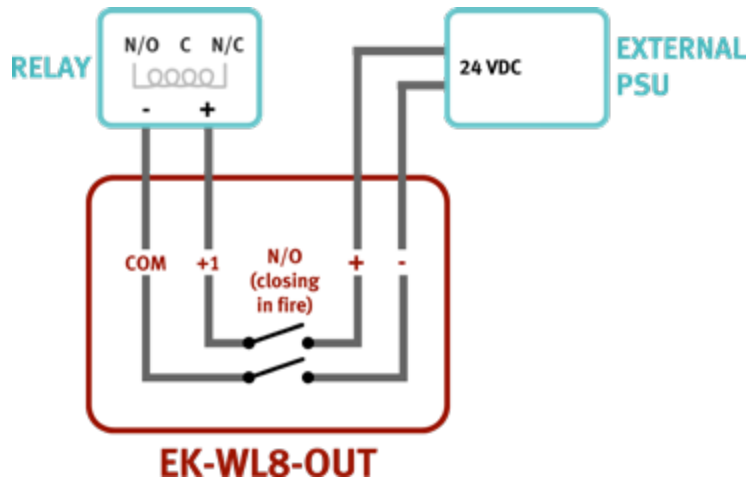

The external PSU will supply the voltage to the power terminals of the Ekho Output Module (rated for 250 VAC but we would recommend only using VDC). When the fire alarm is activated, the Output Module will switch the voltage by closing the two contacts.

The voltage is then transferred to the COM and +1 terminals. Please note that a connection from these terminals to a third party relay unit is required. The voltage will then be applied to the coil of the relay and the contacts will operate

\*Dependant on operational usage \*2Supply voltage dependant



# EK-WL8-OV/AU

## Hybrid Wireless Optical Smoke Sensor with Built in Voice Annunciator and VAD

### Features

- ▶ Approved to AS ISO 7240 Parts 3, 7, 23 & 25
- ▶ RED compliant
- ▶ Voice Sounder and VAD Incorporated Internal algorithm processing for optimal performance
- ▶ Tamper switch
- ▶ Up to 10 years battery life\*
- ▶ Utilises standard low cost lithium battery technology
- ▶ Bi-directional wireless communications
- ▶ Self optimising wireless amplitude and frequency
- ▶ Compatible with all Ekho Translator/Expander modules.



### Description

The EK-WL8-OV is a wireless optical smoke sensor that incorporates a voice sounder and visual alarm device (VAD) with white LEDs and 0.5 Hz flash rate. The sensor utilises optical smoke detection technologies and algorithms for

improved performance, which can contribute to reducing unwanted alarms. Utilising well-proven adaptive radio signal processing algorithms ensure the highest levels of life safety and system reliability are achieved.

### Specifications

Ordering code	EK-WL8-OV/AU	
Operating frequency range	918 - 926 MHz	
Communication range (in open air)	1200 m	
Modulation type	GFSK	
Operating frequency channels	6	
Max. radiated power	≤ 25 mW	
Number of messages	3 (only one message can be played at any one time)	
Sound pressure level @ 1m	>91 dB(A) for all messages	
Frequency range	500 - 3500 Hz	
VAD LED colour / Rating	White / C-3-2.6	
Flash frequency	0.5 Hz	
Operating temperature range	- 10 °C to + 55 °C	
Max. tolerated humidity	95% RH (non-condensing)	
Weight (g) / Dimensions (mm)	215 / ø 111 x H 74	
Power supply (Dual 3V lithium batteries)	1 x Primary cell (CR123A)	1 x Secondary cell (CR123A)
	1.2 Ahr	1.2 Ahr
	Up to 10 years primary battery life*	8 months secondary battery life

### Standards & Approvals

AS ISO 7240-3: Sounders

AS ISO 7240-23: Visual Alarm Devices

AS ISO 7240-7 Smoke Detectors

AS ISO 7240-25: Components using radio links



\*Dependant on operational usage



ISS1 OCT20

For further information visit [www.hochikiaustralia.com/ekho](http://www.hochikiaustralia.com/ekho)

Hochiki Australia Pty Ltd. reserves the right to alter the specification of its products from time to time without notice. Although every effort has been made to ensure the accuracy of the information contained in this document it is not warranted or represented by Hochiki Australia Pty Ltd. to be a complete and up-to-date description.



# EK-WL8-TRH/AU

## Hybrid Wireless Translator Module

### Features

- ▶ Approved to AS ISO 7240 Parts 17, 18 & 25
- ▶ RED compliant
- ▶ Loop Powered
- ▶ OLED Graphical Display
- ▶ Integral Loop Short Circuit Isolator
- ▶ Bi-directional wireless communication
- ▶ Self-optimising wireless amplitude and frequency
- ▶ Tamper switch
- ▶ Flexible on site device adjustment
- ▶ Makes additions to existing wired systems easy and cost effective.



### Description

The EK-WL8-TRH/AU is a fully intelligent wired to wireless Translator Module. Compatible with the Hochiki ESP protocol, the module allows the use of fully intelligent radio (wireless) field devices alongside standard hard wired devices.

The Translator Module allows the connection of up to 126\* Expanders and radio field devices to an addressable fire detection loop. Multiple Translators can be used on a system providing the system has sufficient loop power and addresses available.

The Translator Module incorporates a Loop Short Circuit Isolator and an OLED display to allow the Translator to be easily programmed.

Each radio field device takes a loop address making them fully intelligent and their radio connectivity transparent to the end user. System parameters are programmed via the Translator Module and a PC link. The Translator Module automatically manages sensor radiated power depending on the device communication quality. The unit is fitted with two Internal antennas which reduce radio fade and ensure reliable radio communication. Optional back box available.

### Specifications

Ordering code	EK-WL8-TRH/AU	Optional Back box is available EK-BBOX-01
Operating frequency range	918 - 926 MHz	
Communication range (in open air)	1000 m	
Modulation type	GFSK	
Operating frequency channels	6	
Max. radiated power	≤ 25 mW	
Time period between wireless signal transmissions	2 minutes	
Current consumption	27 mA	
Operating voltage	17 - 41 VDC	
Max. tolerated humidity	95% RH (non-condensing)	
Operating temperature range	- 10 °C to + 55 °C	
Weight (g) / Dimensions (mm)	300 / H 143 x W 210 x D 42 without Back box	

### Standards & Approvals

AS ISO 7240-17 Short Circuit Isolators

AS ISO 7240-25 Components using Radio Links

AS ISO 7240-18 Input/Output Devices



\*Dependant on available loop address capacity



ISS1  
OCT20

For further information visit [www.hochikiaustralia.com/ekho](http://www.hochikiaustralia.com/ekho)

Hochiki Australia Pty Ltd. reserves the right to alter the specification of its products from time to time without notice. Although every effort has been made to ensure the accuracy of the information contained in this document it is not warranted or represented by Hochiki Australia Pty Ltd. to be a complete and up-to-date description.



# EK-WL8-SND/AU

## Hybrid Wireless Sounder

### Features

- ▶ Flexible modular design
- ▶ Approved to AS ISO 7240 Parts 3 & 25
- ▶ RED compliant
- ▶ Bi-directional wireless communication
- ▶ Self optimising wireless amplitude and frequency
- ▶ Tamper Switch
- ▶ 4 Tone Settings
- ▶ Up to 10 year battery life\*
- ▶ Easy to install



### Description

The EK-WL8-SND/AU is a Wall Sounder equipped with our wireless modular alarm device range and is equipped with 4 tones which can be set locally at the sounder as well as volume control to allow for effective communication.

When configured onto an Ekho Translator, the Wireless Sounder is fully addressable and benefits from intelligent monitoring functionality.

### Specifications

Ordering code	EK-WL8-SND/AU	
Operating frequency range	918 - 926 MHz	
Communication range (in open air)	≤ 1200 m	
Modulation type	GFSK	
Operating frequency channels	6	
Max. radiated power	≤ 25 mW	
Time period between wireless signal transmissions	2 minutes	
Number of tones	4 (set via DIL switch on the unit)	
Max. sounder output	93 dB(A) @ 1 metre	
Max. tolerated humidity	95% RH (non condensing)	
Operating temperature range	- 10 °C to + 55 °C	
Dimensions (mm)	H 90 x W 90 x D 97	
Power supply (Dual 3V lithium batteries)	1 x Primary cell (CR123A)	1 x Secondary cell (CR123A)
	1.2 Ahr	1.2 Ahr
	Up to 10 years primary battery life*	8 months secondary battery life

### Standards & Approvals

EN54-3 Sounders

AS ISO 7240-25 Components using radio links



\*Dependant on operational usage



ISS1  
OCT20

For further information visit [www.hochikiaustralia.com/ekho](http://www.hochikiaustralia.com/ekho)  
Hochiki Australia Pty Ltd. reserves the right to alter the specification of its products from time to time without notice. Although every effort has been made to ensure the accuracy of the information contained in this document it is not warranted or represented by Hochiki Australia Pty Ltd. to be a complete and up-to-date description.

# ekho

## EK-WL8-SK/AU

### Hybrid Wireless Survey Test Kit

#### Features

- ▶ Robust carry case
- ▶ Easy to use (training is required before purchase)
- ▶ Allows for surveying potential hybrid wireless installations.



#### Description

This Ekho test kit consists of a portable wireless translator, a wireless smoke sensor and a keypad.

The keypad displays the wireless communication signals between the

sensor and the translator module, enabling you to design a wireless system successfully.

Power supply not included.

#### Specifications

Ordering code	EK-WL8-SK
Weight (kg) / Dimensions (mm)	5.35 / H 430 mm x W 370 mm x D 160 mm

#### Standards & Approvals

